



**Verrier**  
SPA

**1.63TL**

TELESCOPIC  
WHEEL  
LOADER



# VENIERI

## 1.63TL

### Venierina



#### HEAVY DUTY TELESCOPIC BOOM

New concept boom and kinematic (*VENIERI TELESCOPIC PARALLEL KINEMATIC*) designed for heavy duty activities, that ensure **safety** and **reliability** in any application, especially on heavy ones.



#### 360° 3D VIEW

Full control of the whole working area as well as front and rear attachments, thanks to the **360° visibility** of the Venieri Cabin.



#### AUTOMOTIVE DISC BRAKE SYSTEM

**Disc Brake system**, usually used on big loaders only, to ensure a strong breaking performance.



#### 3 CABINS 3 OPTIONS JUST 1 MACHINE

It's possible to choose between **3 different types of cabin**, to better meet customers' needs.



#### LED LAMP

**Next-gen led lamps**, as used in automotive applications.



#### PERFECT STABILITY

**Rear oscillating axle** and central articulation (heavy-duty, oversized, designed for 6-7 tons machines).



#### VROOOOOOM!

**40 km/h driving speed**. As this machine is coming from the Italian Motor Valley, *the speed is standard!*



#### REAR TOOL CARRIER

The machine can be equipped with multiple hydraulic and electric lines, to use **rear attachments**.



#### 50 HP OF PURE JAPANESE POWER

**Yanmar** engine, inline-four cylinder, aspirated, STAGE IIIA/Tier III, ables to deliver **high torque at low rpm**.



#### TYRE RANGE FOR ANY KIND OF APPLICATION

**Wide range of tyres** selected for any kind of terrain and application: both industrial and agricultural.



# 1.63TL

## TELESCOPIC WHEEL LOADER



### DIESEL ENGINE

Engine: 4 cylinders, direct injection, water cooled, paper dry filter.

Emissioned according to Directive CE 97/68 stage IIIA.

Type	Yanmar 4TNV88	
Max power	36kW - 50 HP	
Rated rpm	3.000	
Net power ISO/TR 14396	35 kW - 48 HP	
Net power EEC/80/1269	35 kW - 48 HP	
Economic working range	1200 - 1800 rpm	
Max. torque	Nm	141
Bore	mm	88
Stroke	mm	90
Displacement	cm <sup>3</sup>	2.190



### ELECTRIC SYSTEM

Battery	12 Volt	
Capacity EN 60095-1	80 Ah - 770 A	
Alternator rating	55 A	
Reverse warning	<b>Standard</b>	
Wiring according to	IP 67 - DIN 40050	



### TRANSMISSION

Hydrostatic transmission with automatic power regulation and closed circuit with variable-displacement pump and engine. Two forward/reverse speeds with single-lever control.

Speed	Forward	Backward
1 <sup>st</sup> gear km/h	0 ÷ 8	0 ÷ 8
2 <sup>nd</sup> gear km/h	0 ÷ 40*	0 ÷ 40*

\* with 420/55 R17 tyres



### AXLES

Two heavy duty axles with planetary final drives in each wheel. All wheel drive. Fixed rigid drive axle on front chassis section. Oscillating drive axle on rear chassis section up to a total angle of 20°.

Transfer gearbox transferring movement directly to the rear and to the front via a transmission shaft. Self-locking limited slip differential on front axle (optional on rear axle).



### BRAKES

**Service:** disk brake hydraulically operating on front axle, working on all wheels. **Parking brake:** mechanical disk brake operating on service brake, manually actuated.



### TYRES

Standard	31x15.50 -15
Optional	12.0 - 16,5 • 420/55 R17



### STEERING

Servo assisted steering hydraulic **LOAD SENSING** system.

Total steering angle	90°	
Inner tyres turning radius	mm	1.554 (1.600)*
External tyres turning radius	mm	3.174 (3.136)*
External bucket turning radius	mm	3.608

\* Values with 12.0-16,5 tyres.



### HYDRAULIC SYSTEM

Hydraulic gear pump with **LOAD SENSING** priority valve for steering circuit. 4-section modular control valve with main relief valve. Double-acting hydraulic cylinders.

Hydraulic oil cooling radiator. Full-flow oil filter on the return line. Single cloche-lever arm control with 4 position lifting system and with 3 position bucket system, auxiliary system and telescopic function by switch.

Max flow	lt/1'	58
Loader relief valve pressure	bar	190
Steering relief valve pressure	bar	210



### TELESCOPIC ARM

Telescopic boom with Z-bar linkage and compensation integrated in the lifting cylinder to ensure parallelism.

- Anti-tipping device and safety block valves
- Telescopic boom cylinder inside the telescopic arm
- Ride control and floating function on request



### SERVICE CAPACITIES

Engine	lt	8
Front axle	lt	5,8
Rear axle + gear box	lt	6,5
Hydraulic circuit	lt	50
Brake system	lt	1,1
Fuel	lt	50
Water cooling	lt	9



### TECHNICAL FEATURES

Standard bucket capacity	m <sup>3</sup>	0,5
Standard bucket width	mm	1.600
Straight static tipping load	kg	2.300
Full turned 45° tipping load	kg	1.980
Hinge pin height (telesc. retracted)	mm	3.045 (3.070)*
Hinge pin height (telesc. extended)	mm	3.901 (3.925)*
Dump height at 37° (telesc. retracted)	mm	2.311 (2.335)*
Dump height at 37° (telesc. extended)	mm	3.167 (3.190)*
Reach at 37° (telesc. retracted)	mm	857 (840)*
Reach at 37° (telesc. extended)	mm	1.313 (1.295)*
Maximum loading height with forks (telesc. extended)	mm	3.673 (3.700)*
Breakout force	kg	2.700
Forks static tipping load, full turn	kg	1.562
Payload EN 474-3 (80%) [A]	kg	1.250
Payload EN 474-3 (60%) [A]	kg	937

[A] Loading center 500mm



### DIMENSIONS AND WEIGHTS

Max length in transfer position	mm	4.800
Max width in transfer position	mm	1.600
Max height	mm	2.232 (2.250)*
Track width	mm	1.180 (1.170)*
Overall tyre width	mm	1.580 (1.495)*
Ground clearance	mm	322 (345)*
Wheel base	mm	1.950
Standard operating weight	kg	3.600
Max permissible weight	kg	4.000

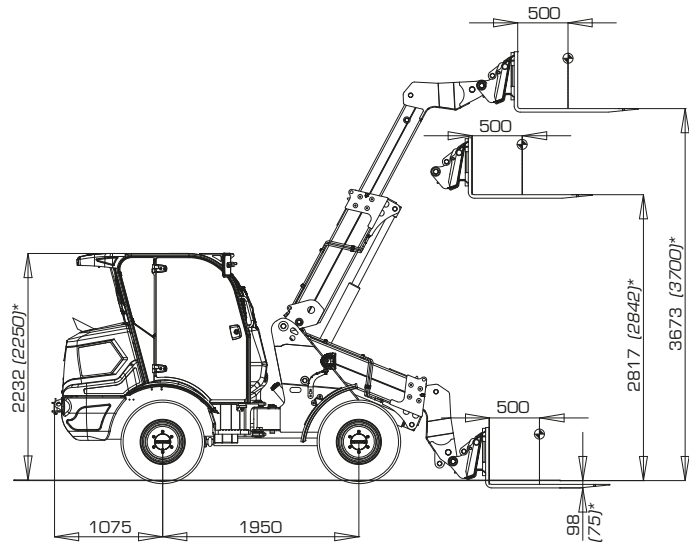
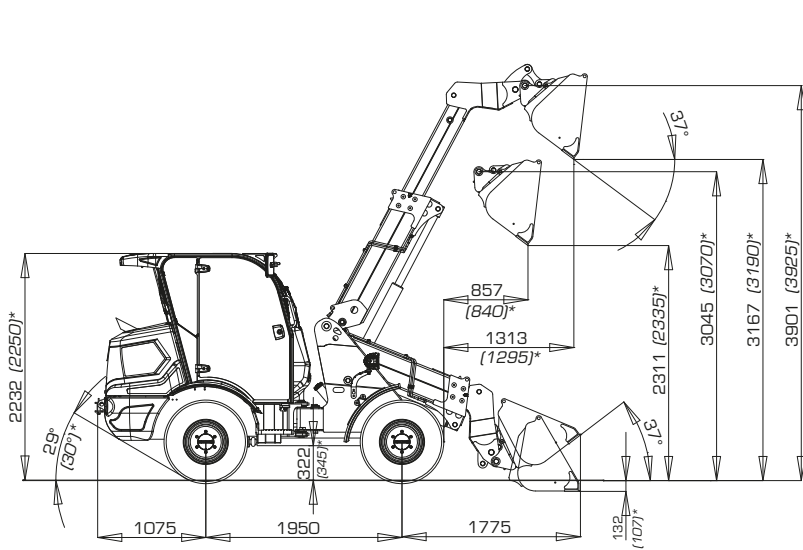

\* Values with 12.0-16,5 tyres.

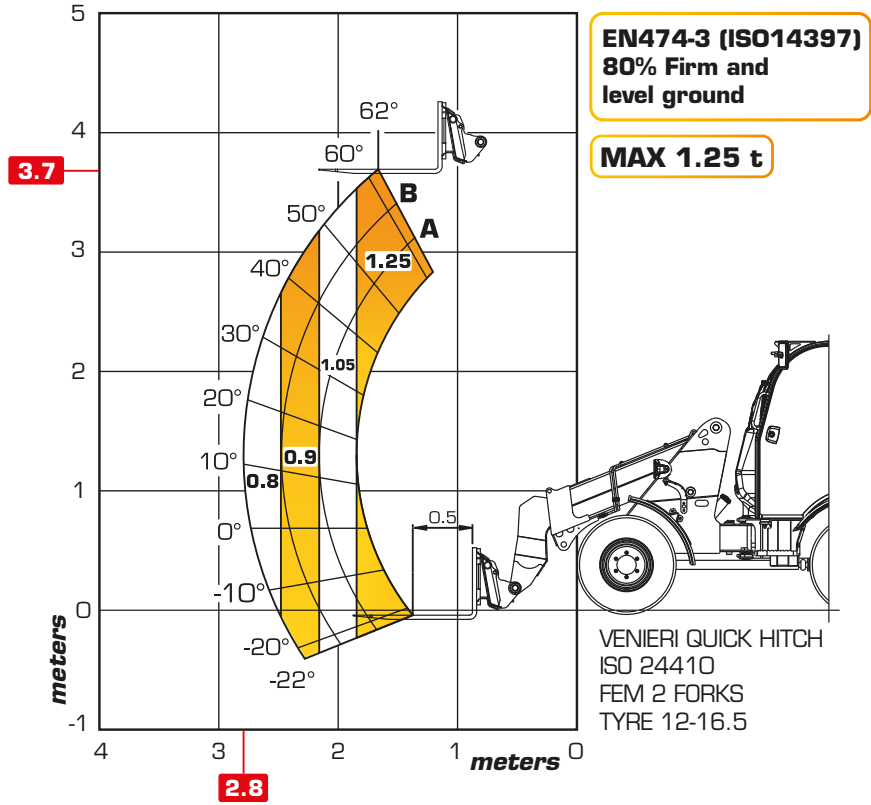
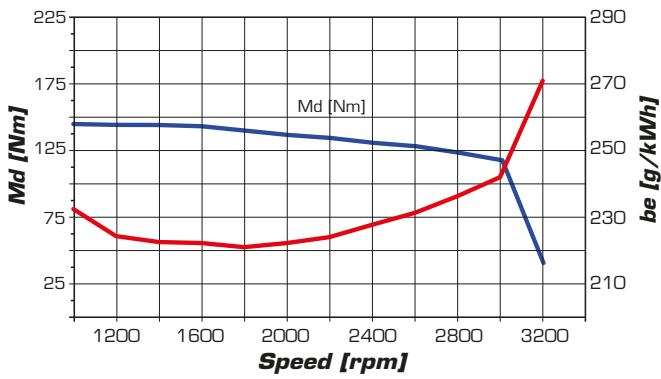
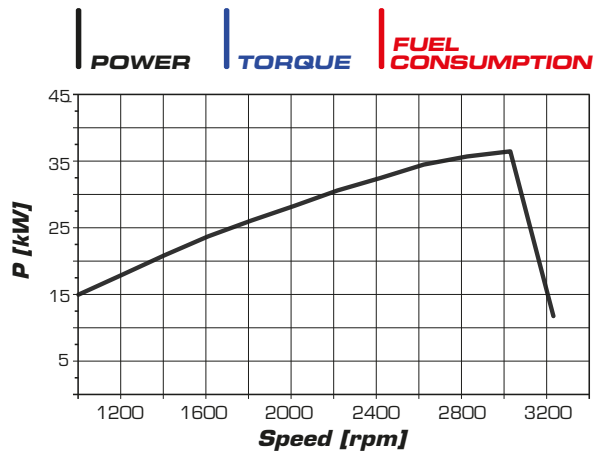



**EURO**  
QUICK COUPLER



**SKID**  
QUICK COUPLER

## STANDARD QUICK COUPLING\*

\* EQUIPMENTS AVAILABLE ON STOCK

Wide range of quick coupler and hydraulic and electric option, suitable to connect every type of attachments.



## VENIERI REAR HYDRAULIC LINE

In order to grant maximum versatility, the machine can be equipped with rear Hydraulic line, to supply remote attachments.

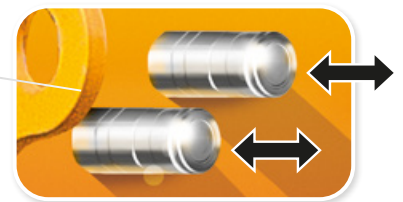

## SETUP ON DEMAND

The new telescopic loader can be configured with **3 different cabin models (ROPS / FOPS I)**, to adapt it to **any working condition**.

### CABIN

CLOSE AND HEATED CABIN, WITH AIRCONDITION IN OPTION.



### CANOPY

CANOPY WITH RETROFITTABLE GLASS AND DOORS.



### ROLLBAR ROOF

FOLDABLE ROLLBAR.



**BASIC  
MACHINE**

Battery main switch	✓	Anti-tipping device	✓
Tool box	✓	Safety block valves on lifting and bucket cylinders	✓
Fuel preheating (cold climates)	○	Speed selection on joystick	✓
Plugs with keys for fuel and hydraulic tanks	✓	Inch pedal integrated in brake pedal	○
Proportional self lock front differential	✓	Selection F/N/R on joystick	✓
Proportional self lock rear differential	○	Transmission selector on column steering	✗
Recovery hitch	✓	40 km/h travel speed	✓
Warning beacon	✓	Service brake that works on both axles	✓
Twin beacons LED	○	Automatic centralized greasing system	○
Soundproofing	✓	Ride control	○
Spare parts catalogue	✓	Floating mode	○
User manual	✓	Bucket and lifting proportionally controlled	✓
Type-approval for road traffic	✓	Auxiliary ON/OFF controlled	✓
European Agricultural Tractor type approval (167/2013 - Mother Regulation)	✗	Engine preheating system	○
Safety clamp for bucket and lifting cylinders	✓	Environmentally-friendly hydraulic oil	○
Speed reduction kit	○	Hydraulic oil ISO 46 (cold climates)	○
"Venieri GLOBAL" system	✗	Cyclone dust separator	○
Double-speed hydraulic fan	✗	Road lights front and rear	✓
Reversible fan (for radiator cleaning)	✗	Boom worlights	○
Hydraulic negative parking brake	✗	Plastic front and rear fenders	✓

**CABIN  
EQUIPMENT**

Foldable Roll-Bar homologated ROPS/FOPS I	○	Buzzer	✓
4 post Canopy homologated ROPS/FOPS I	✓	Cabin carpet	✓
Closed cabin homologate ROPS/FOPS I, pressurized and soundproofed	○	Radio preparation (only for closed cabin)	✓
Front and rear windscreen wiper with washer (only for closed cabin)	✓	Supplementary socket 12V	✓
Double entrance door	✓	Manual Air Conditioning	○
Rear openable window (only for closed cabin)	✓	"Climatronic Venieri" system	○
LED work lights (2 front + 2 rear)	✓	Ceiling lamp (only for closed cabin)	✓
Mobile phone compartment	○	Sun visor	○
Document compartment	✓	Rear view mirrors	✓
Seat with mechanical suspension	✓	Heatable rear view mirrors	○
Seat with pneumatic suspension	○	First-aid kit	○
Seat with pneumatic suspension and heating	○	Fire extinguisher 2kg	○
Seat armrests (LH)	✓	Seat belt	✓
Adjustable armrest (RH) for joysticks	✓	Instrumentation and dashboard with LCD display	✓
		Tilting column steering	✓
		Safety glass breaker	○

**SPECIAL  
EQUIPMENT**

Hydraulic quick coupler SKID (ISO 24410)	○
Hydraulic quick coupler EURO	○
Digging bucket	○
Light material bucket	○
Cement mixing bucket	○
Multipurpose bucket (4 in 1)	○
Lifting forks	○
Root rake with grapples	○
Grab for wrapped bales	○
Snow blade and "V" type snow blade	○
Angle-tilt dozer blade	○
Unpressurized return pipe on fixed boom	○
Double auxiliary line	○
Rear electrics	○
Rear auxiliary	○

# STANDARD EQUIPMENTS\*

\* Equipments available on stock; others on request.



**SWEeper**



**GRAPPLE FORK**



**GRAPPLE BUCKET**



**LASER ANGLE DOZER BLADE**



**GRAB FOR WRAPPED BALES**



**ROUND BALE FORK**



**PALLET FORK**



**LIFTING FLOATING FORK**



**HIGH VOLUME BUCKET**



**4 IN 1 BUCKET**



**ANGLE DOZER BLADE**



**SNOW BLADE**



**ANGLE ROLL SWEPER**



**MIXING BUCKET**



**FRONT CUTTING HEAD**



**GRASS CUTTER**

The illustrations on the present folder do not necessarily show the product standard version. Data and dimensions described in this folder are not binding. Venieri reserves the right of carrying out possible changes at any time and without previous notice because of its policy of steady development and improvement of the products.



Via Piratello, 106 - 48022 Lugo (RA) - ITALY  
Tel. +39 0545 904411 Fax +39 0545 30389  
e-mail: info@vf-venieri.com | [www.vf-venieri.com](http://www.vf-venieri.com)

**Spare Parts**  
Tel. +39 0545 904429 Fax +39 0545 24555  
e-mail: ricambi@vf-venieri.com